

DCR/OFFICE OF THE ZONING ADMINISTRATOR/COMPLIES WITH THE REQUIREMENTS OF DC ZONING REGULATIONS (11 DCMR)

*8/3/2018*

DISTRICT OF COLUMBIA PERMITTING DIVISION STRUCTURAL WORK IN GENERAL APPROVED SUBJECT TO THE FURTHER APPROVAL OF CONSTRUCTION

NOTES:

Structural Engr. Section

DISTRICT OF COLUMBIA PERMITTING DIVISION STRUCTURAL WORK IN GENERAL APPROVED SUBJECT TO THE FURTHER APPROVAL OF CONSTRUCTION

MAR 29 2018

Date Structural Engr. Section

FLOOR PLANS

300 E ST NE, WASHINGTON D.C.

SCALE: 1/8" = 1'-0"

A0-02

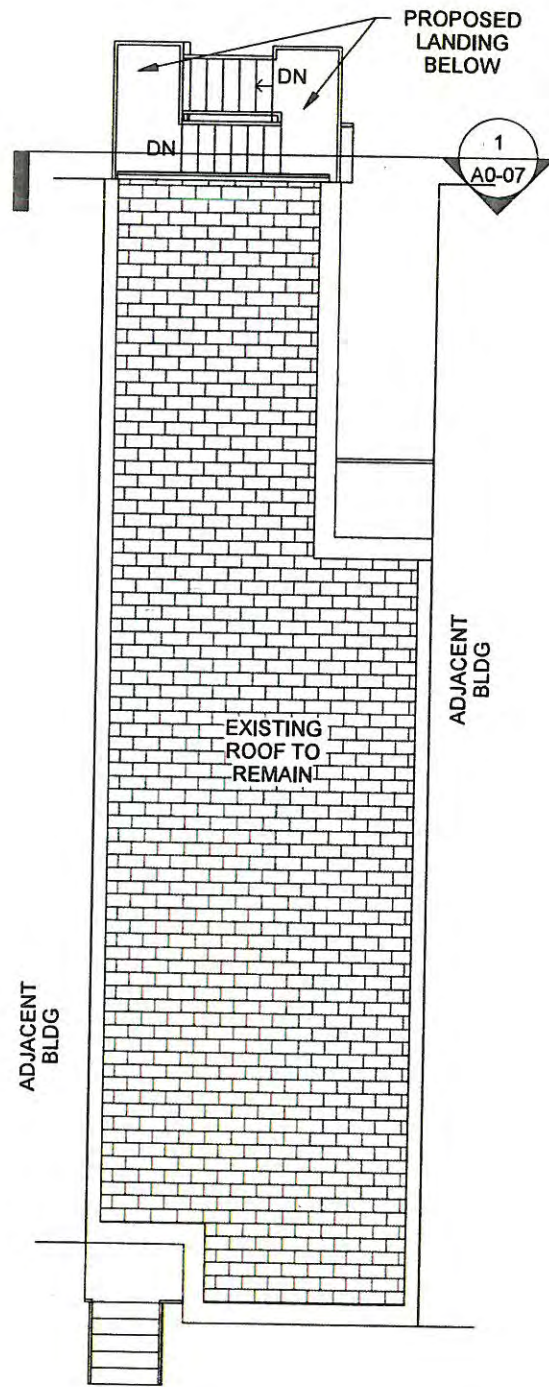

2/ ROOF PLAN

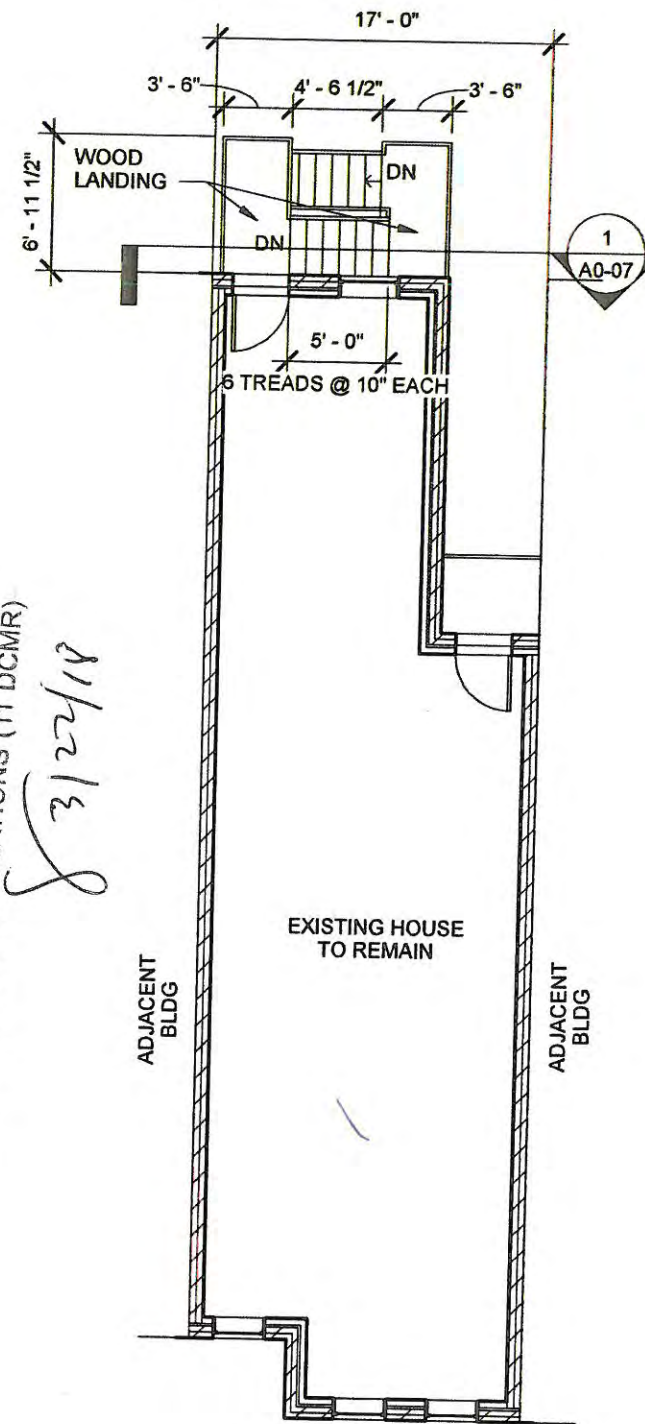

1/ LEVEL 2 PLAN

DCRA/OFFICE OF THE ZONING ADMINISTRATOR/COMPLIES WITH THE REQUIREMENTS OF DC ZONING REGULATIONS (11 DCMR)

*J 3/22/18*

NOTES:

DISTRICT OF COLUMBIA PERMIT PROCESSING DIVISION STOP WORK IN GENERAL APART FROM CONSTRUCTION APPROVAL OF

Structural Engineering Section

MAR 26 2018

Date

FLOOR PLANS

300 E ST NE, WASHINGTON D.C.

SCALE: 1/8" = 1'-0"

A0-03

DISTRICT OF COLUMBIA PERMIT  
 PROCESSING DIVISION STRUCTURAL  
 TO THE FURTHER APPROVED SUBJECT  
 CONSTRUCTION APPROVAL OF  
 Date \_\_\_\_\_  
 Structural Engr. Section

NOTES:

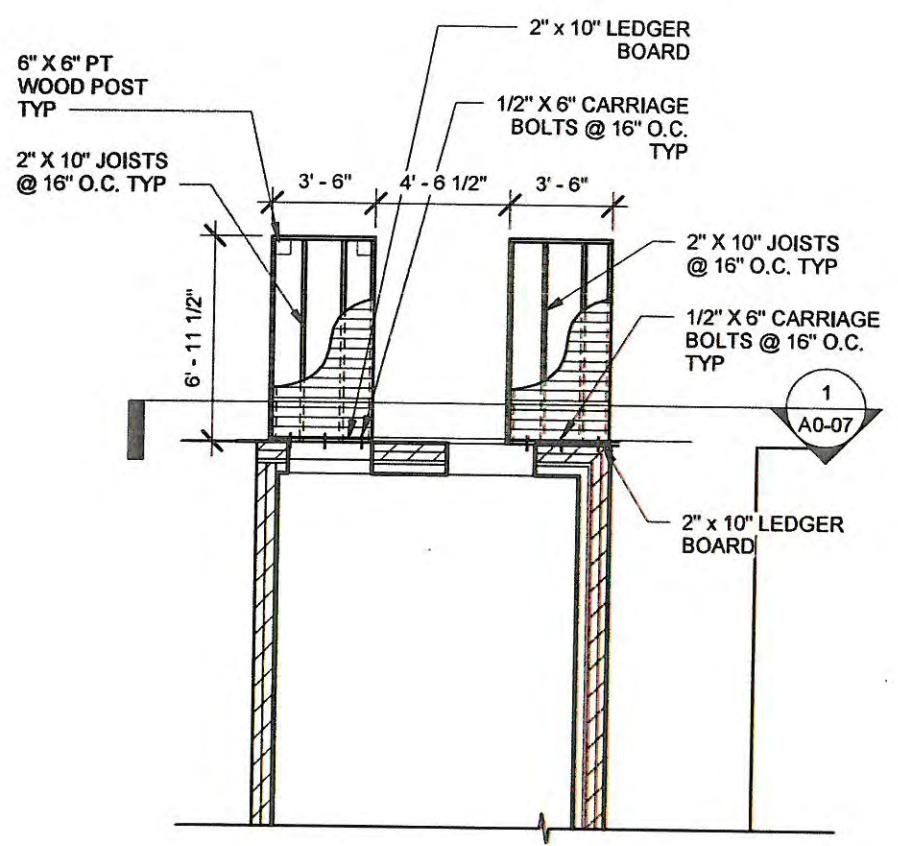

2/ LEVEL 2 FRAMING PLAN

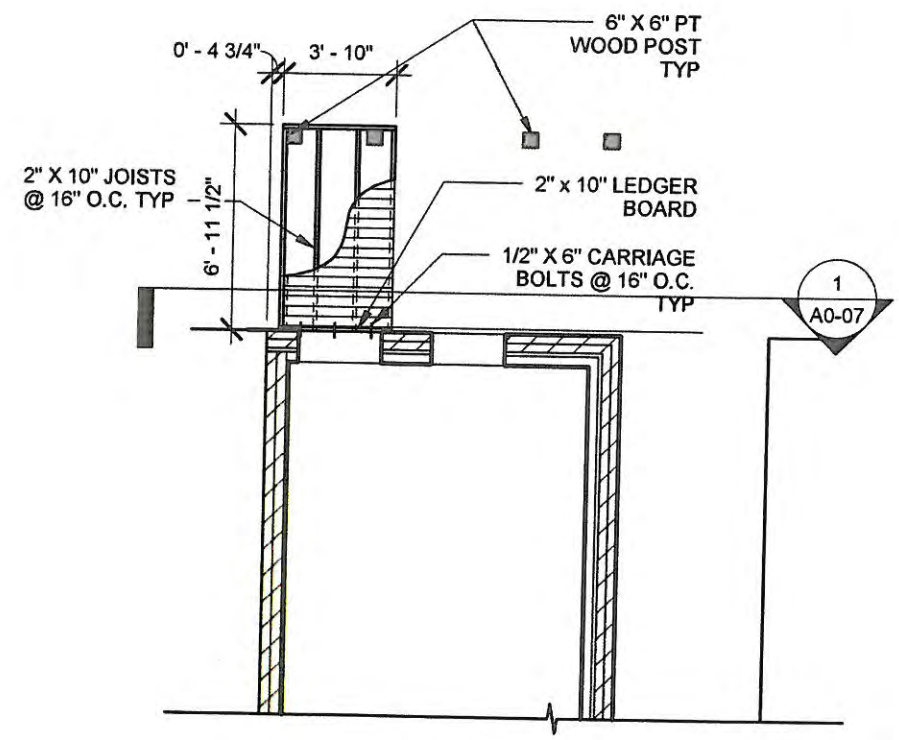

1/ LEVEL 1 FRAMING PLAN

FRAMING PLANS

300 E ST NE,  
 WASHINGTON D.C.

SCALE: 3/16" = 1'-0"

A0-04

DISTRICT OF COLUMBIA PERMIT  
PROCESSING DIVISION STRUCTURAL  
WORK IN GENERAL APPROVED SUBJECT  
TO THE FURTHER APPROVAL OF SUBJECT  
CONSTRUCTION  
Date \_\_\_\_\_  
Structural Engr. Section \_\_\_\_\_

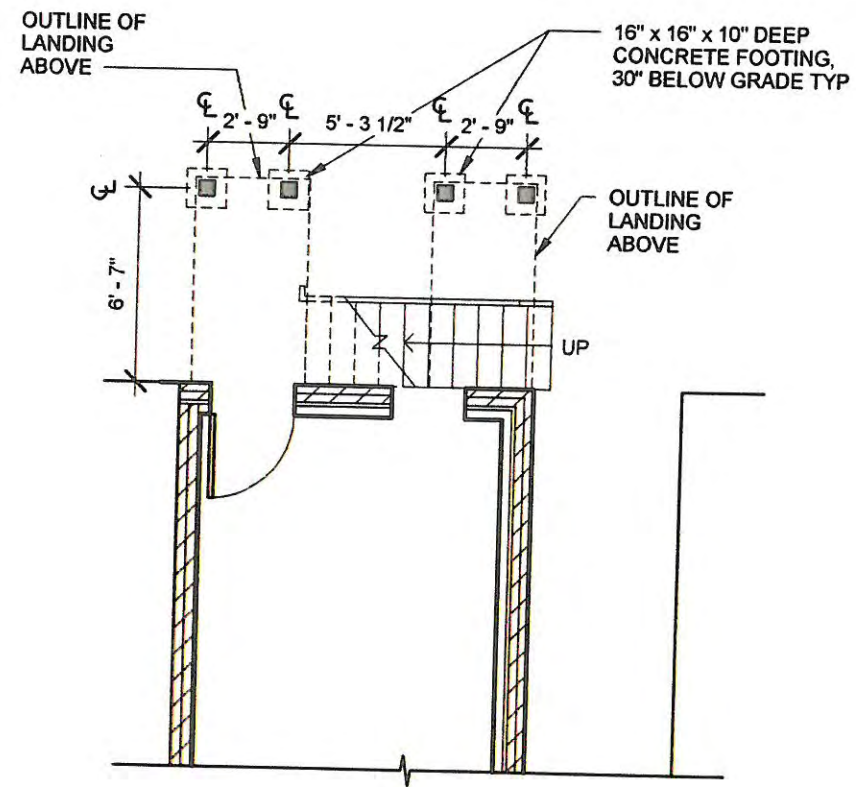

1/ LEVEL 1 FOUNDATION PLAN

NOTES:

FOUNDATION PLAN

300E ST NE,  
WASHINGTON D.C.

SCALE: 3/16" = 1'-0"

A0-05

LORA/OFFICE OF THE ZONING ADMINISTRATOR/COMPLIES WITH THE REQUIREMENTS OF DC ZONING REGULATIONS (11 DCMR)  
 2/3/22/18

DISTRICT OF COLUMBIA PERMIT PROCESSING DIVISION STRUCTURAL WORK IN GENERAL APPROVED SUBJECT TO THE FURTHER APPROVAL OF CONSTRUCTION  
 Date \_\_\_\_\_ Structural Engr. Section \_\_\_\_\_

- NOTES:**
1. REPAIR METAL PORCH AND STAIRS ON THE FRONT OF THE HOUSE
  2. REBUILD P.T. WOOD STAIRS IN THE REAR OF THE HOUSE

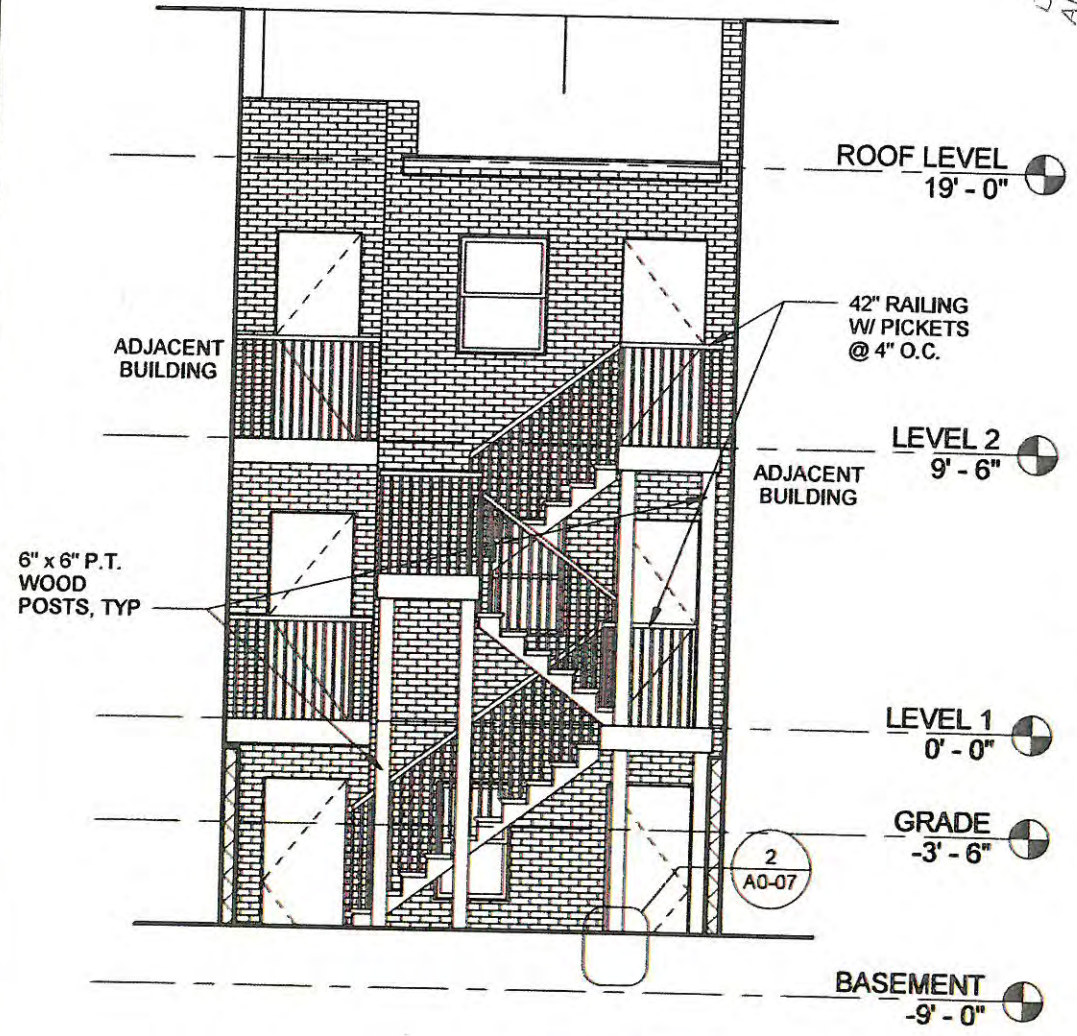

2/ REAR ELEVATION

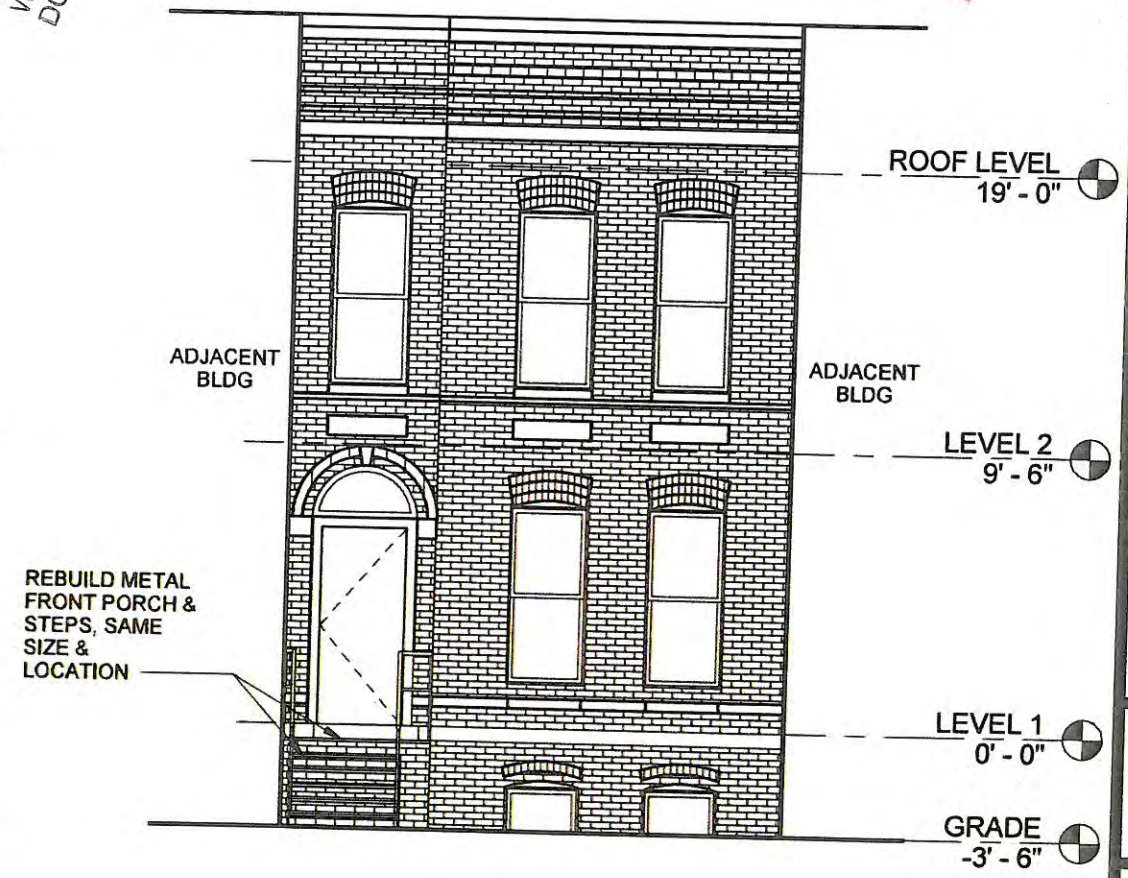

1/ FRONT ELEVATION

DISTRICT OF COLUMBIA PERMIT PROCESSING DIVISION STRUCTURAL WORK IN GENERAL APPROVED SUBJECT TO THE FURTHER APPROVAL OF CONSTRUCTION  
 Date MAR 26 2018 Structural Engr. Section \_\_\_\_\_

ELEVATIONS

300 E ST NE,  
 WASHINGTON D.C.

SCALE: 3/16" = 1'-0"

A0-06

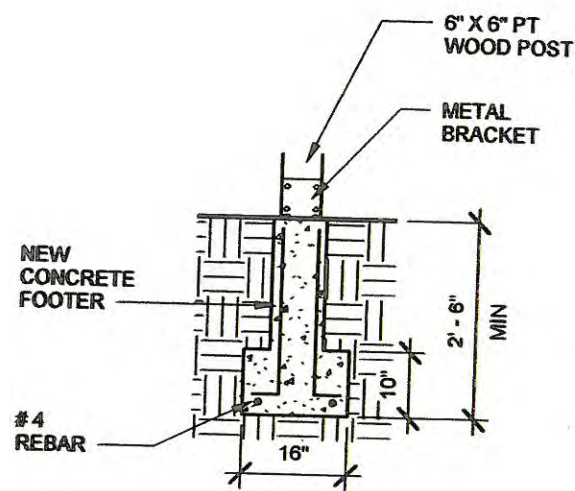

2/ POST FOOTER DETAIL  
SCALE: 1/2" = 1'-0"

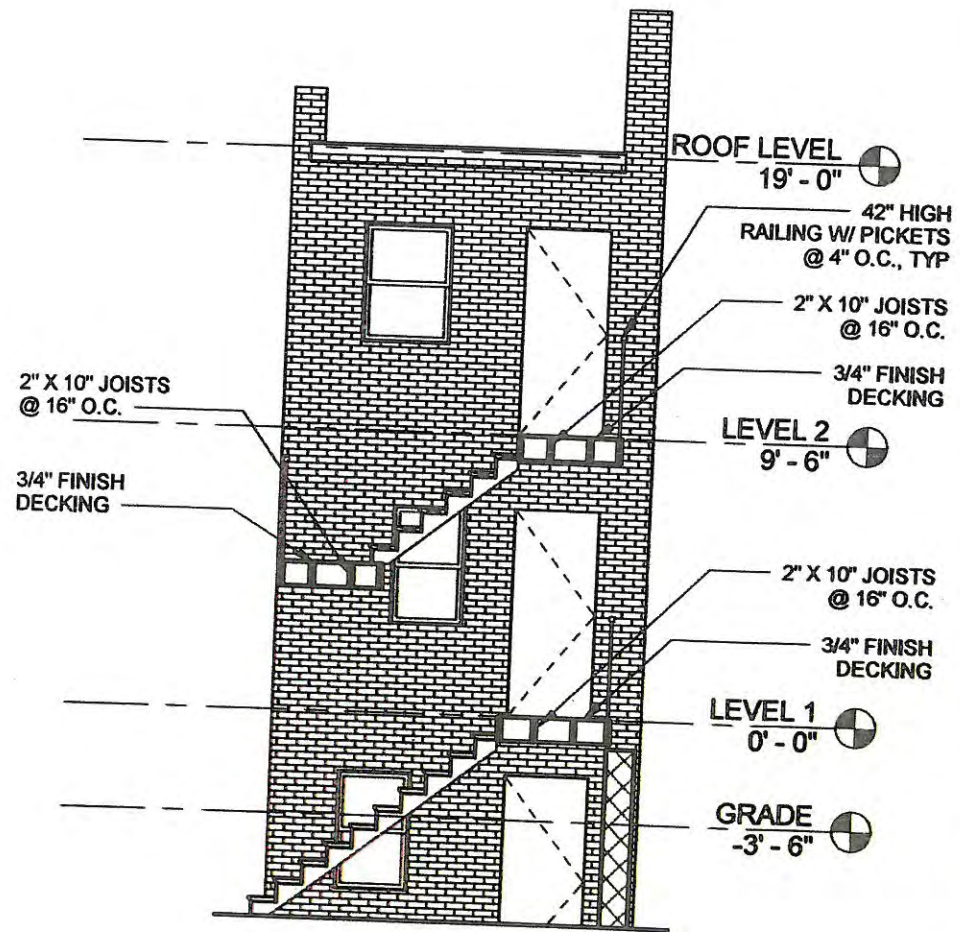

1/ LANDING SECTION  
SCALE: 3/16" = 1'-0"

NOTES:

PERMANENT FILE

DISTRICT OF COLUMBIA PERMIT  
PROCESSING DIVISION STRUCTURAL  
WORK IN GENERAL APPROVED SUBJECT  
TO THE FURTHER APPROVAL OF

Date \_\_\_\_\_  
Structural Engr. Section \_\_\_\_\_

DECK SECTION  
& DETAILS

300 E ST NE,  
WASHINGTON D.C.

A0-07